



## **Measurements of collimator wakefields at End Station A**

J. L. Fernandez-Hernando<sup>1</sup>, S. Molloy<sup>2</sup>, J.D.A. Smith<sup>3</sup>, N. K. Watson<sup>4</sup>

June 27, 2008

### **Abstract**

The angular deflection of a 28.5 GeV electron beam passing off-axis between the jaws of a collimator, generating a transverse wakefield, were measured in End Station A (ESA) at SLAC. In total, fifteen different configurations of collimator geometry and material were tested: some were chosen for compatibility with previous measurements while others served to study the effect of geometry and taper angles (geometrical contribution to the wakefield) and the effect of the material resistivity (resistive contribution) to the imparted kick. This paper summarises the last update of preliminary experimental results before they are finalised. The reconstructed kick factor is compared to analytical calculations and simulations.

**Published in the Proceedings of EPAC'08, Genoa, Italy, June 23-27, 2008**

- 1) STFC, Daresbury Laboratory, Warrington, U.K. (j.l.fernandez.hernando@dl.ac.uk)
- 2) SLAC, Menlo Park, California, U.S.A.
- 3) Cockcroft Institute, University of Lancaster, U.K.
- 4) University of Birmingham, U.K.

## 1 Introduction

Test beams at the End Station A in SLAC were performed to make direct measurement of geometric and resistive wakefields in tapered collimators. A detailed description of these test beams can be found at [1]. Each pair of collimator jaws (with constant half-gap) was moved from an offset of -1.2 mm with respect to the beam being centred in the collimator jaws to an offset of 1.2 mm, in steps of 0.2 mm and stopping at each step enough time to gather data for kick reconstruction. The data taken was grouped by bunch length and collimator number and then analysed for kick reconstruction and extract a kick factor to compare with those predicted by analytical calculations and numerical 3D packages such as GdfidL [2].

## 2 Collimator Geometries measured in the tests

In total fifteen different collimator configurations of geometry and material were tested in four test beam runs performed during 2006 and 2007. The purpose for testing each geometry is the following:

Collimator 1. The same geometry that was used in a previous test beam [3], allowing us to check for consistency of results.

Collimator 2. Same taper angles as collimator 1 but with a reduced gap.

Collimator 3. Again same taper angle but with a 1 m long flat section. The aim of such flat section is to study the resistive contribution to the wakefield.

Collimator 4. Collimator without tapers and a thickness of 0.5 radiation lengths of copper.

Collimator 5. Same geometry as 4 but with a different gap. Straightforward prediction and generates significantly-sized experimental deflection.

Collimator 6. Collimator with a shallower taper angle but same gap as 2 and 5. This collimator was used as common reference between the test beams performed during 2006 and 2007.

Collimator 7. Collimator with a taper angle on its top. This geometry is tested to investigate if material, from a taper which is at a moderate distance from the beam will affect the wakefield in a distinctive way or if the beam kick will be dominated by the material closest to it.

Collimator 8. Same approach as with collimator 7 but adding an extra taper with a larger angle than the one in the top. It was also interesting to see if these geometries could be modelled.

Collimator 10. Using collimator 6 as a reference (same taper angle) this geometry adds a flat top equivalent to 0.6 radiation lengths of titanium alloy based on the needs of an ILC spoiler [4]. The material is copper with a surface finish intentionally roughened ( $Ra \sim 6\mu\text{m}$ ) to investigate the differences between polished and unpolished surface.

Collimator 11. Same as collimator 10 but introducing the titanium alloy material that is the main candidate for the ILC spoilers. It will allow study the effect of different resistivity on the wakefield kick.

Collimator 12. Same as 6 but with polished surface.

Collimator 13. Shorter tapers and with a flat top to study the same effects as with collimator 7.

Collimator 14. Same as 13 but using titanium alloy instead of copper.

Collimator 15. Same as 13 but using a shallower top taper angle.

Collimator 16. A non-linear shaped spoiler that could approximate a definitive more realistic geometry. Interesting for comparison with numerical simulations.

Figures 1 to 4 show the set of four collimators placed in each sandwich. Each sandwich has five slots, four of them containing collimators and one of them empty used for reference measurements. The yellow coloured collimators are made of copper while the grey ones are made of titanium alloy. Collimators in sandwiches 1 and 2 were measured during two test beams in 2006 while collimators in sandwiches 3 and 4 were measured in two test beams in 2007. Collimator 6 was used as reference collimator for the tests in 2007 to assess not only reproducibility of results but also consistency of the data taken.





Collim. #	Side view	Beam view	Revised 4-May-2006
1			$\alpha=324\text{mrad}$ $r=2.0\text{mm}$
2			$\alpha=324\text{mrad}$ $r=1.4\text{mm}$
3			$\alpha=324\text{mrad}$ $r=1.4\text{mm}$
4			$\alpha=\pi/2\text{rad}$ $r=4.0\text{mm}$

Figure 1: Collimators 1 to 4 (placed as in wakebox).



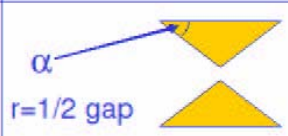
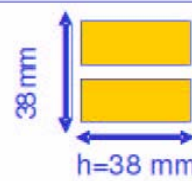

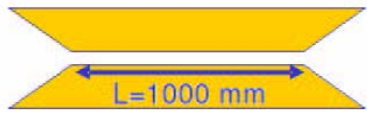

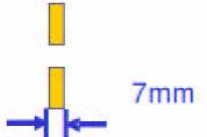
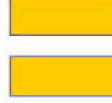
Collim.#	Side view	Beam view	Revised 4-May-2006
8			$r_1 = 4.0\text{mm}$ $r_2 = 1.4\text{mm}$ $\alpha_1 = 289\text{mrad}$ $\alpha_2 = 166\text{mrad}$
7			$\alpha_1 = \pi/2 \text{ rad}$ $\alpha_2 = 166\text{mrad}$ $r_1 = 4.0\text{mm}$ $r_2 = 1.4\text{mm}$
6			$\alpha = 166\text{mrad}$ $r = 1.4\text{mm}$
5			$\alpha = \pi/2 \text{ rad}$ $r = 1.4\text{mm}$

Figure 2: Collimators 5 to (placed as in wakebox).

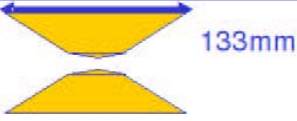
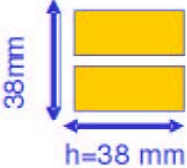



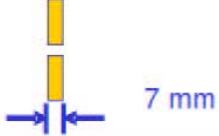

Collim.#	Side view	Beam view	Revised 27-Nov-2006
6			$\alpha = 166\text{mrad}$ $r = 1.4\text{mm}$ (1/2 gap)
10			$\alpha = 166\text{mrad}$ $r = 1.4\text{mm}$
11			$\alpha = 166\text{mrad}$ $r = 1.4\text{mm}$
12			$\alpha = 166\text{mrad}$ $r = 1.4\text{mm}$

Figure 3: Collimators 6, and 10 to 12 (as in wakebox).

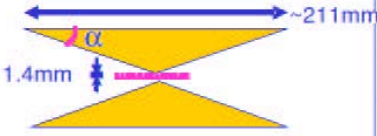
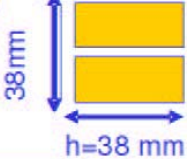

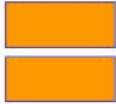

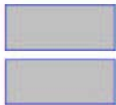
Collim.#	Side view	Beam view	Revised 27-Nov-2006
13	OFE Cu 		$\alpha_1 = \pi/2$ rad $\alpha_2 = 166$ mrad $r_1 = 4.0$ mm $r_2 = 1.4$ mm
14	Ti6Al4V 		$\alpha_1 = \pi/2$ rad $\alpha_2 = 166$ mrad $r_1 = 4.0$ mm $r_2 = 1.4$ mm
15			$\alpha_1 = \pi/2$ rad $\alpha_2 = 50$ mrad $r_1 = 4.0$ mm $r_2 = 1.4$ mm
16	OFE Cu 		non-linear taper $r = 1.4$ mm

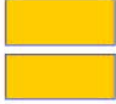
Figure 4: Collimators 13 to 16 (placed as in wakebox).

### 3 Reconstruction of the kicks and data analysis

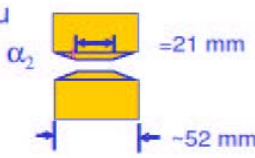
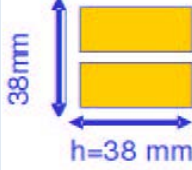
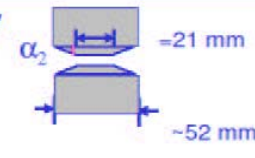
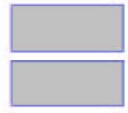
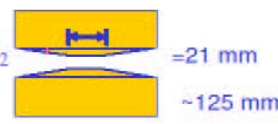
Data from ten BPMs, four upstream of the collimator and six downstream, were used to the reconstruction of the angular deflection of the beam. To reconstruct the kick the slope from a linear fit to the upstream BPM data was subtracted from the slope of a linear fit from the BPM downstream data.

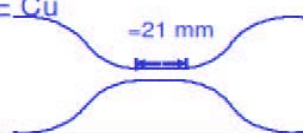
Each collimator was translated vertically from an offset of -1.2 mm to 1.2 mm. The mean deflection at each 0.2mm step in the travel was determined by averaging between 300 and 600 separately reconstructed deflections, recorded at 10Hz repetition rate. A polynomial fit to these data was performed, using cubic and linear terms over the full range of vertical offsets, or limiting to the linear term alone over a reduced range of offsets from -0.6 mm offset to 0.6 mm, where the data exhibit linear behaviour. The kick factor is defined as the linear term of the fit in both cases.

Several different methods of combining the data from different runs to the same collimator were studied. One consists of averaging the deflections at a given collimator offset from statistically independent data taking runs using the same collimator and under nominally identical beam conditions, such as bunch length. This method allows a graphical representation and some examples of this are shown in Fig. 5 and 6. The main potential disadvantage with this kind of analysis is that it is possible that kicks from different collimator offsets are incorrectly combined as from run to run the beam may not be in the same position with respect to the zero position of the collimator, because the feedback set points could have been changed.

Another method was to calculate the kick factor for each individual run by fitting the individual reconstructed kicks, and subsequently averaging these kick factors. This method is independent from the initial beam position with respect to the collimator.

Of these methods of extracting deflections and combining data from different runs, the one that gives the most robust results, and statistical uncertainties on the kick factor around or below 10%, is that which performs linear fits to the reconstructed kicks from each run in the interval  $|\text{vertical offset}| < 0.6\text{mm}$  and then averages all these kick factors from all the different runs performed to the same collimator. Those results are the ones shown in Table 1.

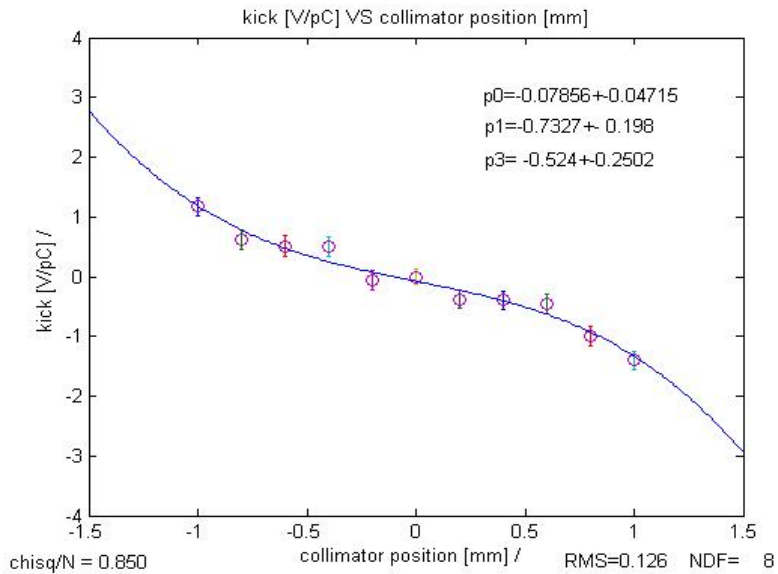

Figure 5: Collimator 6.

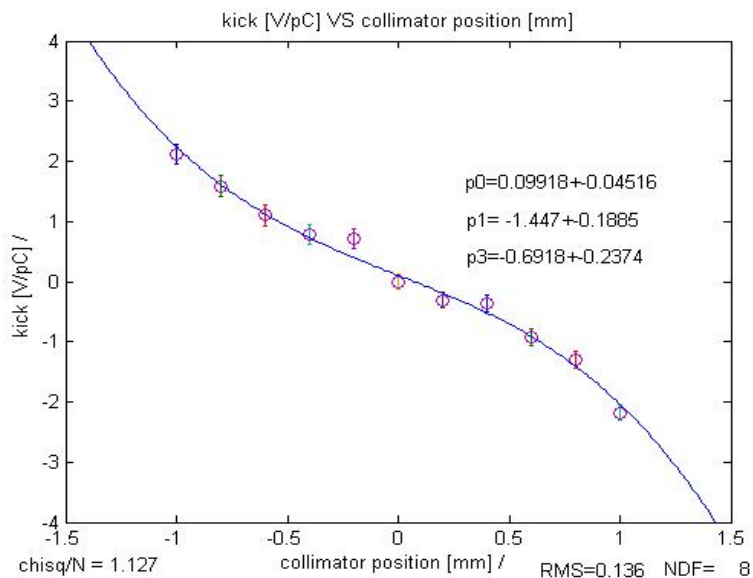

Figure 6: Collimator 12 (same taper angle and material as collimator 6 but with a 2.1 cm long section in the centre).

## 4 Summary of results

The kick factors analysed have a statistical uncertainty on the measurement of typically 10% for most cases. Table 1 also shows the predicted value, calculated with GdfidL [2], which seems to overestimate the kick. Collimator 1 geometry was used in previous test beams [3] giving then a kick factor of  $1.3 \pm 0.1$  V/pC/mm.

GdfidL gives the same result for collimators with same geometry, but different material, because it does not take into account the material resistivity, in the case of the collimators 10 to 12 and 13 to 14 where the difference of material resistivity is evident from the data

The similar kick factor shown by collimators 6 and 8 and the greater kick factor shown by collimator 7, having all these collimators same taper angle (7 and 8 only on its top) indicates that a progressive taper angle approach could be successful in order to mitigate wakefields and, at the same time, save space in the beam line.

Table 1: Reconstructed kick factor from analysis of experimental data (first column) and kick factor calculated using GdfidL [2] (second column) per each collimator.

<b>Collimator</b>	<b>Measured Kick Factor</b> V/pC/mm	<b>3-D Modelling Prediction</b> <b>Kick Factor</b> V/pC/mm
1	$1.2 \pm 0.3$	$1.2 \pm 0.03$
2	$1.9 \pm 0.2$	$3.1 \pm 0.02$
3	$4.4 \pm 0.3$	$5.6 \pm 0.30$
4	$0.6 \pm 0.4$	$0.8 \pm 0.03$
5	$4.9 \pm 0.3$	$5.7 \pm 0.17$
6	$1.0 \pm 0.1$	$2.3 \pm 0.32$
7	$1.4 \pm 0.3$	$2.8 \pm 0.16$
8	$1.0 \pm 0.2$	$2.6 \pm 0.05$
10	$1.4 \pm 0.2$	$2.3 \pm 0.31$
11	$1.7 \pm 0.1$	$2.3 \pm 0.31$
12	$1.7 \pm 0.1$	$2.3 \pm 0.31$
13	$1.9 \pm 0.2$	$3.3 \pm 0.11$
14	$2.6 \pm 0.1$	$3.3 \pm 0.11$
15	$1.6 \pm 0.1$	$2.6 \pm 0.03$
16	$1.6 \pm 0.2$	$1.3 \pm 1.25$

## 5 Conclusions

Additional measurements have been performed at SLAC End Station A to study both geometric and resistive wakefields using fifteen sets of steeply tapering copper and titanium alloy collimators. New predictions from both analytic calculations and numerical models have been made to compare with data. The analysis of the experimental data showed reconstructed kick factors with a precision of better than a 10%.

## Acknowledgement

The authors wish to acknowledge Mike Woods, from SLAC; as well as the nano-BPM group: S. T. Boogert, B. Maiheu, A. Lyapin, M. Slater and Y. Kolomensky.

This work is supported by the Commission of the European Communities under the 6<sup>th</sup> Framework Programme “Structuring the European Research Area”, contract number RIDS-011899.

## References

- [1] N. Watson et al., “Direct Measurement of Geometric and Resistive Wakefields in Tapered Collimators for the International Linear Collider,” contribution MOPLS066 at EPAC2006.
- [2] Warner Bruns Field Computations. <http://www.gdfidl.de>
- [3] P. Tenenbaum et al., Phys. Rev. ST Accel. Beams 10, 034401 (2007).
- [4] L. Fernandez-Hernando, N.K. Watson, “FLUKA simulations of energy density deposition from an ILC bunch in different spoiler designs”. EuroTeV report 2006-015