

VIBRATION STABILITY STUDIES OF A SUPERCONDUCTING ACCELERATING MODULE QUADRUPOLE OPERATING AT 4.5 K

Ramila Amirikas, Alessandro Bertolini, Wilhelm Bialowons
Deutsches Elektronen-Synchrotron DESY, 22603 Hamburg, Germany

Abstract

A new method for low level low frequency vibration measurements in the cryogenic environment is presented. Commercial moving coil seismometers (geophones) have been used to investigate the mechanical stability of the quadrupole of a third generation (so-called Type-III) FLASH cryomodule (named Module 6) in fully operating conditions. Geophones were able to operate at 4.5 K without any loss of performance, providing nanometer level resolution even in the 1-10 Hz frequency band, region not covered by existing data because of the reduced sensitivity of the cooled piezoelectric accelerometers [1]. A preliminary evaluation of the impact of the refrigeration system and of the high power RF on the vibration level of the quadrupole is also presented. The results are of interest for the design of linear accelerator (linac) cryomodules of the International Linear Collider (ILC) [2] and of the European X-ray Free Electron Laser (XFEL) [3], for which the design is a further evolution of the FLASH Type III.

INTRODUCTION

Uncorrelated fast motion of linac quadrupoles could cause beam jitter and may generate emittance growth in the ILC and XFEL. Knowledge of the limits achievable on the mechanical stability of an operating cryomodule is thus relevant for both projects. Systematic studies on mechanical transfer functions, carried out at DESY on room temperature standing alone Type-II [1] and Type-III [4] modules, have already proven the reliability of the inner layout with the cold mass (cavity string plus quadrupole package) supported from above by the helium gas return pipe (GRP). In this work, main focus is on possible noise generated on the quadrupole by the cryogenic system such as broadband acoustic noise, pressure oscillations in the He feed lines etc., and by the high power RF. Geophones, whose application at cryogenic temperatures was almost unexplored in literature, have been evaluated as a suitable choice for low frequency inertial sensors.

GEOPHONES AT 4.5 K

A GS-11D geophone, with 4.5 Hz spring system and 380-ohm coil, from Oyo Geospace [5], was chosen as a good compromise between low resonant frequency and small size (3.4 cm high for 3.2 cm diameter). A geophone basically consists of a sensing coil suspended by a low resonant frequency spring system in an axial magnetic field. When the sensor case accelerates, the coil moves with respect to the fixed magnet. The gradient of the magnetic field transforms (with sensitivity G , in V/m/sec

units) the relative velocity into an electromotive force, which can be measured with a shunt resistor R_d in series. As a complementary effect, the flowing current generates a linear force, opposite to the direction of the coil motion which produces a strong mechanical damping on the spring system.

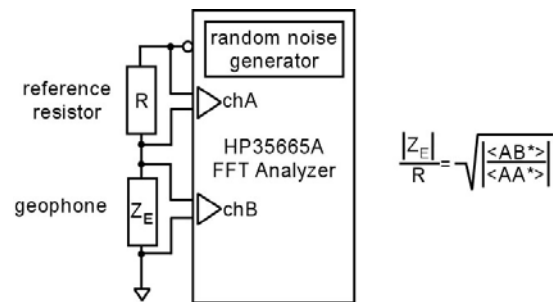

Figure 1: Block diagram of the calibration setup.

The frequency response of the output voltage V_{out} versus case inertial velocity v_g is determined by the sensor mechanics and by the load/damping resistor according to:

$$\tilde{V}_{out}(\omega) = \left(\frac{R_d}{R_d + R_{coil}} \right) \frac{-\omega^2 G}{\omega_0^2 - \omega^2 + j \frac{\omega \omega_0}{Q_l}} \tilde{v}_g(\omega) \quad (1)$$

where R_{coil} is the resistance of the coil, ω_0 is the resonance of the spring system and Q_l is the loaded mechanical quality factor.

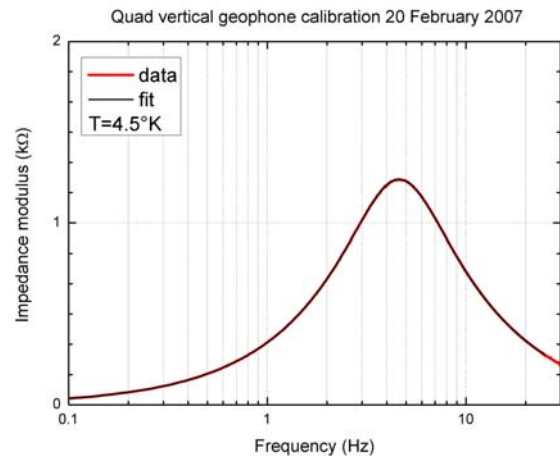

Figure 2: Calibration curve of the vertical geophone measured at 4.5 K during the test run of Module 6.

In this simplified model the coil inductance is neglected. In the standard configuration, flat velocity output with

low frequency cut-off at ω_0 is achieved by adjusting R_d to get $Q_1 \sim 0.7$. Geophones can be remotely calibrated, using the signal cable itself. This aspect was essential for the use of the device at cryogenic temperatures because the changes of the electromechanical parameters with the cooldown were almost unpredictable. The method giving the most complete information [6] consists of measuring the electrical impedance Z_E versus frequency seen at the output terminals of the geophone. In this setup (see Fig.1), a random noise current was injected through the series between a reference resistor and the geophone, and the transfer function between the voltages across the two impedances was measured with a HP35556A FFT analyzer. The input impedance of the instrument was also taken into account in the calculations. Data were compared, with a least squares fit, to the following model:

$$Z_E(\omega) = R_{coil} + j\omega L + \frac{j\omega G^2 / m}{\omega_0^2 - \omega^2 + j\frac{\omega\omega_0}{Q_u}} \quad (2)$$

where L is the coil inductance and Q_u is the mechanical unloaded quality factor. This model is very accurate (see an example of calibration curve in Fig.2) and both electrical and mechanical parameters of the sensor can be extracted, if the suspended mass m is known (the factory quoted value of 23.6 gr has been used in the calculations). Table 1 shows comparison between the parameters of the vertical geophone mounted aboard the Module 6 quadrupole, measured at room temperature and at 4.5 K.

Table 1: Geophone on quadrupole parameters

Parameter	300 K	4.5 K
G (V/m/s)	32.2 ± 0.02	32.28 ± 0.02
R_{coil} (Ω)	387 ± 0.9	10 ± 1
R_d (k Ω)	1.82	4.3
f_0 (Hz)	4.138 ± 0.001	4.624 ± 0.001

The value of the damping resistor used at two different temperatures is also indicated. Besides the expected drop of the coil resistance and the expected increase of the mechanical resonant frequency (due to the increase of the Young modulus of the spring material), no loss of sensitivity was found with respect to room temperature operation.

MODULE 6 ON THE TEST BENCH

FLASH Type-III Module 6, equipped with a ~ 27 MV/m average gradient superconducting cavity string, and with the latest generation piezo tuners, is the most advanced cryomodule in operation. The experiment was carried out during the 10th and 11th thermal cycles of the module thermal and RF test run at the Cryomodule Test Bench (CMTB) facility in DESY. The vertical displacement power spectral density (PSD) at different positions (CMTB floor, top of the vacuum vessel and quadrupole) was measured and the spectra were integrated to obtain root mean square (rms) displacement. All the data sets (both cold at different RF power levels and the warm

reference ones) were taken during daytime of working days for the sake of consistency.

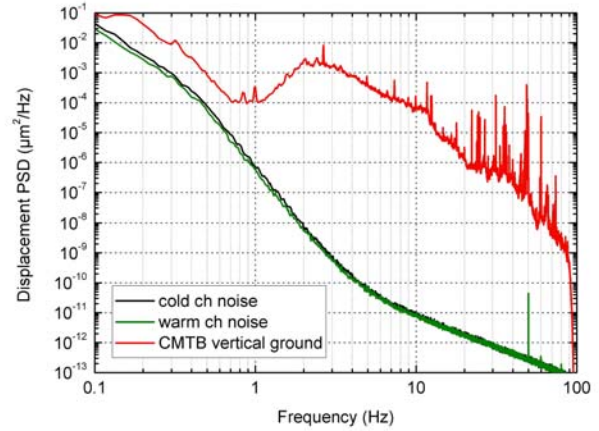

Figure 3: Comparison between the noise of the data acquisition system (amplifier+ADC) and the vertical ground spectrum measured at CMTB in the morning of a working day.

In the setup, a vacuum relieved GS-11D vertical geophone was affixed to the front face of the quadrupole helium vessel, while SM-6 type geophones, having similar specs, were used as warm sensors. A suitable amplifier has been built to extend the frequency band of the device down to 0.5 Hz, combining a linear low-noise preamplifier with an analog inverse filter stage, which provides compensation for the drop $\sim \omega^2 / \omega_0^2$ of the response below 4.5 Hz.

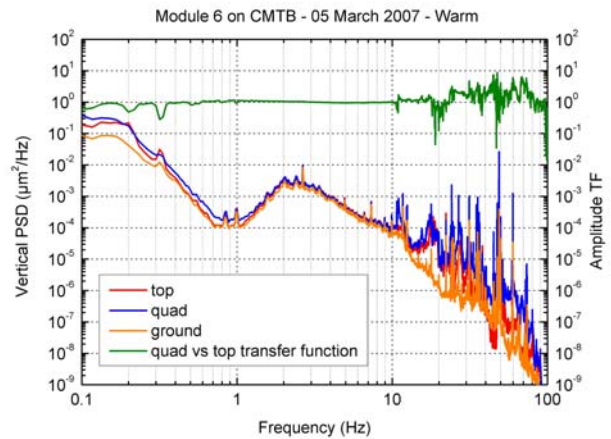

Figure 4. Room temperature PSD spectra measured simultaneously on the CMTB floor, on top of the vacuum vessel and on the quadrupole, quad vs vessel top transfer function is also shown.

Signals were digitized with a six channel 24-bit DM-24 Güralp ADC at 200 S/s sampling rate; spectral analysis was performed with Visual BasicTM routines. This setup ensured a noise level better than $1 \text{ nm}/\sqrt{\text{Hz}}$ at 1 Hz (see Fig.3), measured by replacing the geophone with a resistor of the same value as the signal coil. A few hours

of data were taken at room temperature as reference (see Fig.4). In the frequency range 1-10 Hz, the PSD of the quadrupole vertical motion is shaped by the DESY local seismic activity. Amplification of the ground motion occurs due to the effect of the cryostat support (see the coupling with the 11 and 18 Hz rocking modes and the vertical resonance at 27 Hz), while the vertical mechanical transfer function from the cryostat to the quadrupole looks flat at least up to 40 Hz, where structures appear. Technical noise sources dominate at higher frequencies (at 48.6 Hz the strongest line from the insulation vacuum pump).

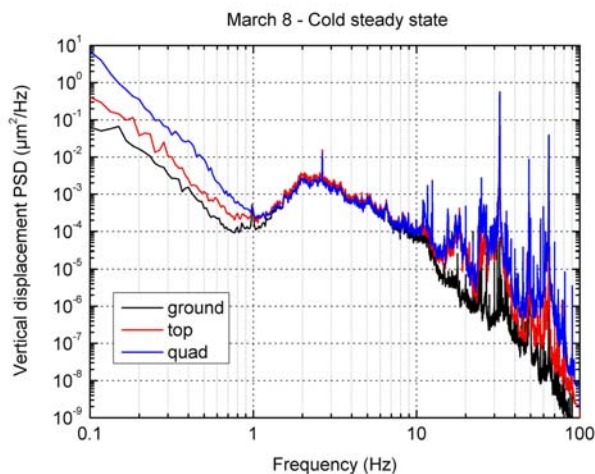

Figure 5: PSDs of ground, vessel top and quadrupole in cold steady state with RF off, measured just after reaching the cold stable conditions at the end of the 11th cooldown.

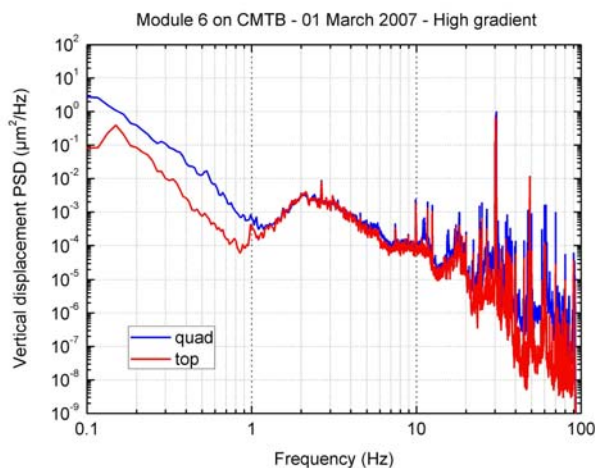

Figure 6: PSDs measured on vessel top and on quad during high power RF tests: the klystron was running at 10 Hz and the average gradient achieved was ~27 MV/m.

No impact from the refrigeration system and from high power RF was found up to 30 Hz in the vibration spectra during cold operation, i.e. cavity string at 2 K and quadrupole cooled at 4.5 K (see Fig.5 and 6). At higher frequencies, onset of a strong anharmonic vibration, with fundamental frequency ~30 Hz, detectable both inside and outside the cryostat and on the hall floor was observed.

The source has been identified so far as a thermal acoustic oscillation originated by a dual capillary flow sensor, with direct transition to room temperature, installed outside of the cryomodule upstream of the inlet valve of the quadrupole 4.5 K feed line [7]. A clear correlation between the vibration amplitude (ranging from 200 nm up to one micron rms on the quadrupole) and the settings of the same valve was in fact discovered.

CONCLUSIONS

Commercial geophones have been successfully operated at 4.5 K aboard the superconducting quadrupole of a FLASH Type III cryomodule. Low noise performance in the 1-10 Hz range and a reliable remote calibration method have been demonstrated. A continuous monitoring of the FLASH linac cryomodules with vertical and horizontal geophones is planned to confirm over the whole 1-100 Hz band the promising results on quadrupole stability achieved in this test at the CMTB.

ACKNOWLEDGEMENTS

The authors would like to thank DESY Cryogenic Division for the support in the setup of the experiment in the CMTB facility, Marcus Kubczigk and Heiko Ehrlichmann for providing software tools. This work is supported by the Commission of the European Communities under the 6th Framework Programme “Structuring the European Research Area”, contract number RIDS-011899.

REFERENCES

- [1] R. Amirikas, A. Bertolini, W. Bialowons, H. Brück, “Quadrupole vibration measurements of a TESLA Type II cryomodule”, EUROTeV Report 2006-036 (2006).
- [2] ILC Reference Design Report (2007), <http://www.linearcollider.org/>.
- [3] European XFEL Technical Design Report (2006).
- [4] R. Amirikas, A. Bertolini, W. Bialowons, “Vibration stability studies of a superconducting accelerating module quadrupole at room temperature”, these proceedings.
- [5] <http://www.geospacelp.com>.
- [6] F.van Kann, J. Winterflood, Rev. Sci. Instrum., 76, p.34501 (2005).
- [7] Rolf Lange and Bernd Petersen, DESY cryogenic division, private communication.